



www.agbudget.co.uk Luxury Swimming Pool Kits & Equipment at Budget Prices

Eco Heat Pumps

Pool & Spa

Duratech[®] Heat Pumps



The ideal solution for heating your swimming pool and spa.



Highly efficient and economical

The energy is collected from the air outside and transferred to the pool water. For each kW consumed by the DURATECH® heat pump, 4 to 6 kW are returned to the pool.

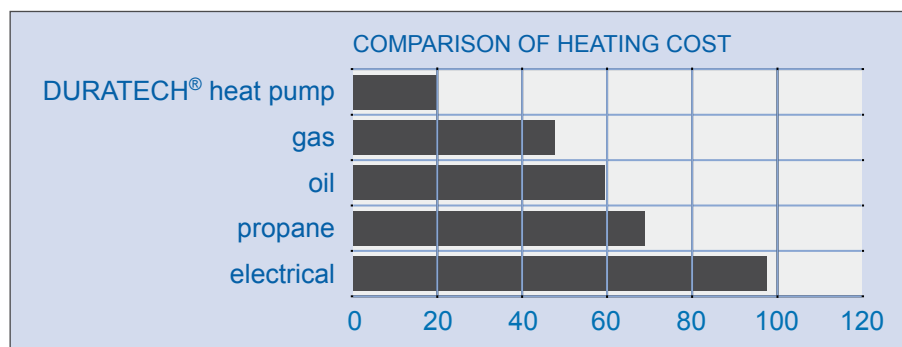

Use

The DURATECH® heat pump must be installed outside. It will heat the pool from April to October and will even work efficiently with outside temperatures as low as -10°C for DURA+ range and 7°C for DURA range heat pumps. Our DURA+ heat pumps have as extra feature a cooling mode, which allows the water to be cooled down by the DURATECH® heat pump as well.

Environment

- ° DURATECH® heat pumps are less harmful to the environment because 80% of the energy produced is collected from the outside air and therefore purely natural.
- ° Also the gas used, R410a (DURA+) R407C (DURA), has no harmful effect on the ozone layer.
- ° Our DURA heat pumps are very energy efficient, our DURA+ range even reach a COP value of 6.

Constructed for durability and longevity

Using advanced and high quality materials like PVC, stainless steel and titanium for the heat exchanger means it is resistant to corrosion through chlorine or salt. The heat exchanger is oversized to improve efficiency.



Easy installation

The unit is intelligently designed and remarkably compact for easy installation. The heatpump has to be installed on a by-pass after the filtration pump.

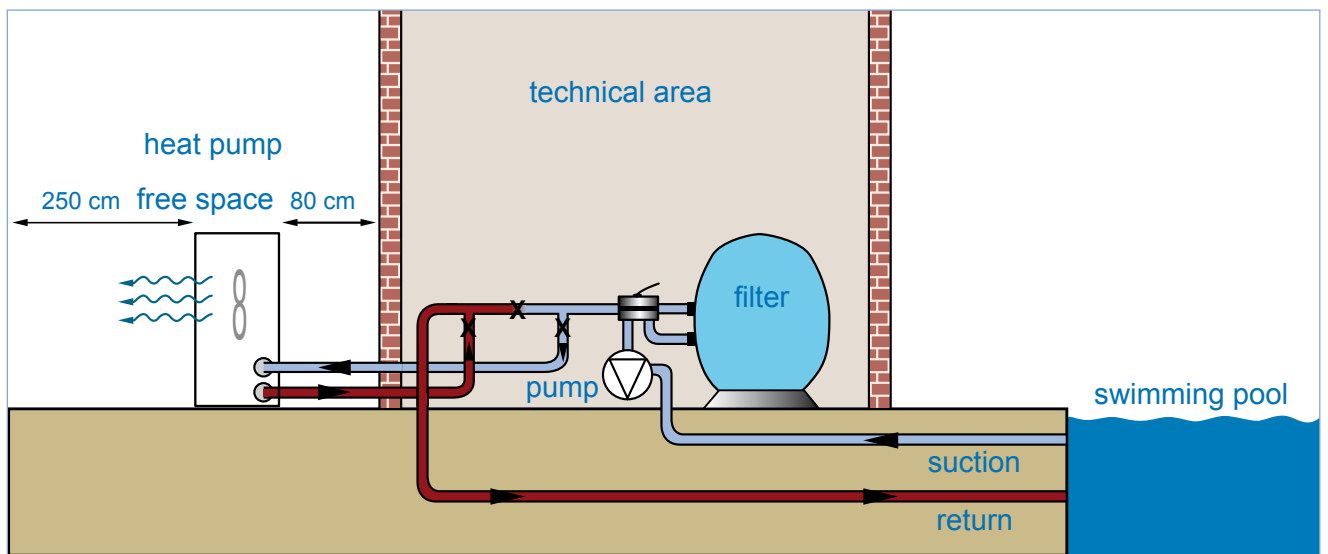

Advanced control

The integrated microprocessor monitors all the sensors and controls the device without any intervention of the user. Electronic display and control with easy operation is standard. The integrated flow switch will sense the water flow and automatically start the heater when the pool pump starts and stops when the pump shuts off.



Running quietly

The use of a highly efficient, low sound rotary or scroll compressor, a low noise fan and an oversized heat exchanger, makes the unit to be extremely quiet in operation. Example: the DURA 8 at 10m distance gives only 32 db(A).



DURATECH® heat pumps can save you up to 80% in operating costs. Whether you just want to extend your swimming season or swim all season in a warm comfortable pool, the DURATECH® heat pump can pay for itself in just a few years with the operation costs savings.

How does it work?

DURATECH® heat pumps utilize the sun's free heat by collecting and absorbing energy from the outside air. This energy is then transferred to the pool water. Your existing pool pump circulates the water through the heater and warms the pool. The unit contains a fan that draws in outside air and directs it over the surface of the EVAPORATOR (energy collector). The liquid refrigerant within the EVAPORATOR coil absorbs the heat from the outside air and the refrigerant becomes a gas. The warm gas passes through the compressor where it is compressed to form a very hot gas, which then passes through the CONDENSER (water heat exchanger). It is here that the heat exchange occurs as the hot gas gives up the heat to the cooler swimming pool water circulating through the coil.

The pool water becomes warmer and the hot gas is cooling down as it flows through the CONDENSOR coil, returns to its liquid form and, after passing through the expansion valve, the whole process begins again.

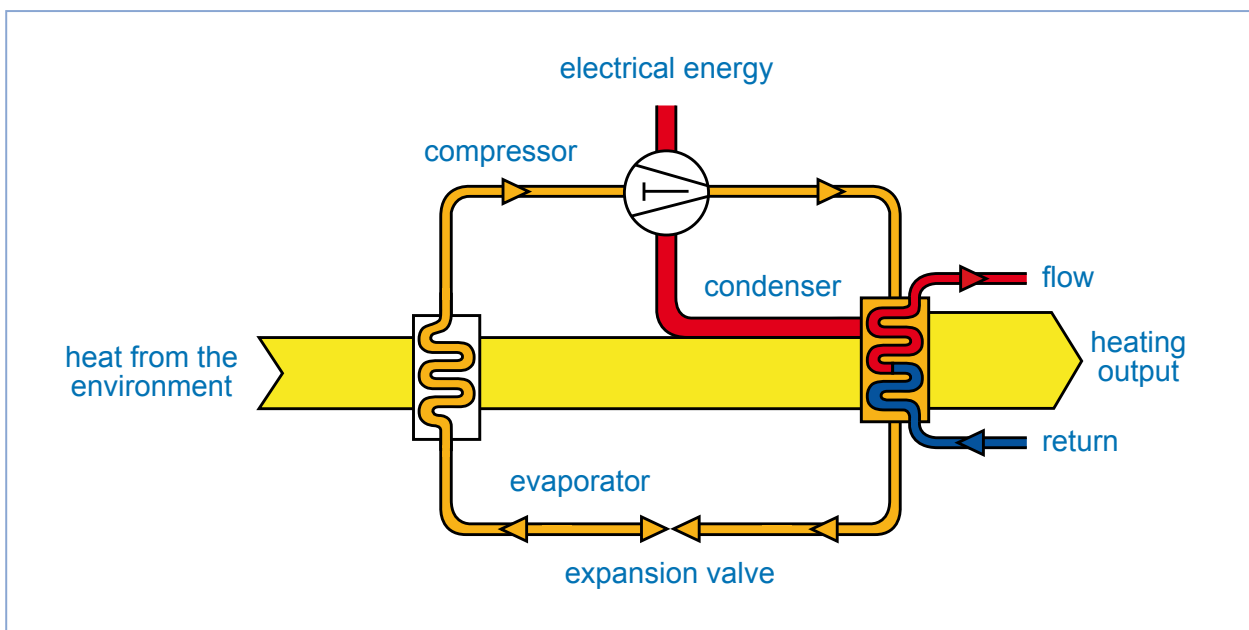

DURA vs DURA+ heat pumps

FUNCTION
TEMPERATURE RANGE
CAPACITY
COP 25A/25W
TEMPERATURE CONTROL
CONTROL
GAS
BODY
HEAT EXCHANGER

DURA
heating
7 up to 45°C
7 - 26kW
5,5
digital
electronically
R407c
steel, coated
titanium

DURA+
heating/cooling
-10 up to 45°C
9,8 - 30kW
6
digital
electronically
R410a
stainless steel/plastic
titanium



UNIT	Model	DURA 7	DURA 10	DURA 13	DURA 18	DURA 22	DURA 22T	DURA 26T
part number		0892651	0892652	0892653	0892654	0892655	0892656	0892657
	kW	7	10	13	18	22	22	26
heating capacity A25/W25	BTU/h	24000	34000	44500	61500	75000	75000	89000
	kW	6,4	9,1	11,8	16,5	20,2	20,2	24,2
heating capacity A15/W25	BTU/h	22000	31000	40500	56500	69000	69000	83000
power input	kW	1,45	2,02	2,63	3,6	4,45	4,45	5,2
maximum volume	m ³	30	40	60	80	90	90	120
running current	A	6,6	9,2	12,1	16,5	20,9	7,9	8,9
maximum current	A	6,6	9,3	13,4	18,7	21	7,1	9,5
COP at A25/W25		5,5	5,5	5,5	5,5	5,5	5,5	5,5
power supply	V/Ph/Hz	220-240/1/50	220-240/1/50	220-240/1/50	220-240/1/50	220-240/1/50	380/ 3/ 50	380/ 3/ 50
controller	Electronic							
condensor	Titanium heat exchanger							
compressor quantity		1	1	1	1	1	1	1
compressor type		Rotary	Rotary	Rotary	Scroll	Scroll	Scroll	Scroll
refrigerant		R407c	R407c	R407c	R407c	R407c	R407c	R407c
air flow high	m ³ /h	1800	2100	2300	3200	4500	4500	4500
air flow low	m ³ /h	1650	1800	2000	2700	3800	3800	3800
fan quantity		1	1	1	1	1	1	1
fan power input	W	25	30	60	200	200	200	200
fan speed	RPM	950/750	950/750	950/750	830/750	830/680	830/680	830/680
fan direction		horizontal	horizontal	horizontal	vertical	vertical	vertical	vertical
noise level	dB(A)	54	54	54	55	57	57	57
water connection	mm	50	50	50	50	50	50	50
nominal water flow	m ³ /h	3-5	5-7	6-8	8-10	10-12	10-12	11-13
maximum pressure loss	kPa	12	15	15	16	16	16	16
nett dimensions	L/B/H mm	936/360/550	1010/370/615	1110/470/680	660/660/860	660/660/960	660/660/960	660/660/960
shipping dimensions	L/B/H mm	1090/390/580	1170/415/645	1165/485/780	700/740/1010	700/740/1110	700/740/1110	700/740/1110
net weight/shipping weight	Kg	54/57	63/67	99/104	108/120	111/123	111/123	112/125

DURA 7 / DURA 10 / DURA 13



DURA 18 / DURA 22
DURA 22T / DURA 26T





Specifications DURA+ heat pumps

UNIT

	Model	DURA 10+	DURA 14+	DURA 19+	DURA 22+T	DURA 30+T
part number		0892045	0892046	0892047	0892048	0892049
	kW	9,8	14,3	19,6	22	30
heating capacity A25/W25	BTU/h	33450	48500	75000	66500	102000
	kW	9,5	13,5	18,6	20,7	28
heating capacity A15/W25	BTU/h	32400	46000	63500	70600	95500
	kW	7,6	12,0	16,4	17,6	24,0
cooling capacity A25/W25	BTU/h	26000	41000	56000	60000	82000
power input	kW	1,71	2,46	3,44	3,67	5,00
maximum volume	m ³	40	60	80	95	130
running current	A	7,43	10,70	14,96	6,10	8,30
maximum current	A	9,30	13,40	18,70	7,10	9,50
COP at A25/W25		5,70	5,80	5,70	6,00	6,00
COP at A15/W25		5,25	5,30	5,25	5,50	5,50
power supply	V/Ph/Hz	220-240/1/50	220-240/1/50	220-240/1/50	380/3/50	380/3/50
controller		Electronic				
condensor		Titanium heat exchanger				
compressor quantity		1	1	1	1	1
compressor type		Rotary	Rotary	Scroll	Scroll	Scroll
refrigerant		R410a	R410a	R410a	R410a	R410a
air flow high	m ³ /h	2100	2300	3200	4500	4500
air flow low	m ³ /h	1800	2000	2700	3800	3800
fan quantity		1	1	1	1	1
fan power input	W	120	120	120	215	215
fan speed	RPM	850/750	850/750	850/750	820/680	820/680
fan direction		horizontal	horizontal	horizontal	vertical	vertical
noise level	dB(A)	51	54	54	57	57
water connection	mm	50	50	50	50	50
nominal water flow	m ³ /h	3,0	4,5	6,0	14,0	19,0
maximum pressure loss	kPa	10	10	10	16	17
nett dimensions	L/B/H mm	905/420/650	905/420/650	1200/470/850	660/660/960	660/660/960
shipping dimensions	L/B/H mm	1030/440/700	1030/440/700	1240/480/900	700/740/1110	700/740/1110
net weight/shipping weight	Kg	60/65	77/82	117/128	112/122	123/133

DURA 19+ / DURA 22+T / DURA 30+T

DURA 10+ / DURA14+

